

# HEADER/CEILING DETAILS

Applies to:
(S) Sliding
(SB) Sliding Bypassing
(SW) Sliding Wall
(SWW) Sliding Wing Wall
(SP) Sliding Pocket
(SPW) Sliding Pocket Wall

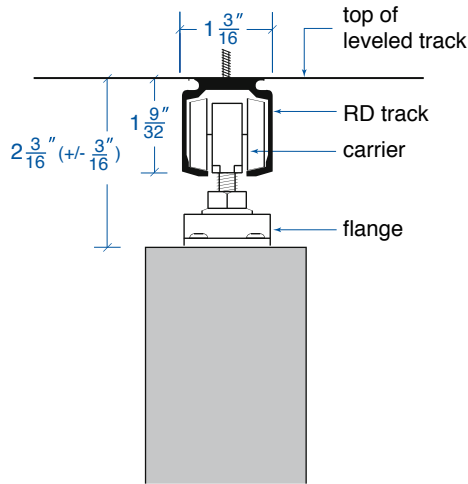

## Sliding Standard

Our standard RD sliding track comes in clear anodized aluminum. Quiet running nylon wheels are mounted directly to the top of the door via surface mounted flange.

Applies to:
(S) Sliding
(SB) Sliding Bypassing
(SW) Sliding Wall
(SWW) Sliding Wing Wall
(SP) Sliding Pocket
(SPW) Sliding Pocket Wall

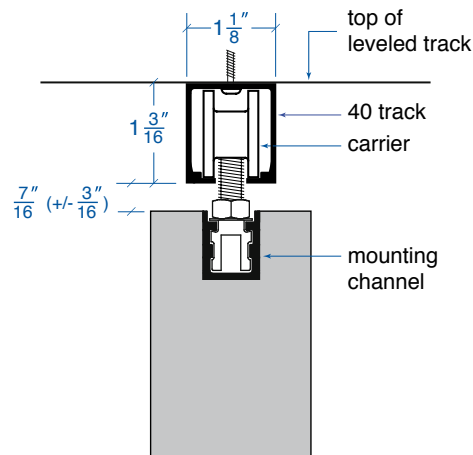

## Sliding Low Profile

Our premium 40/b low profile track comes in clear anodized aluminum. Silent running nylon wheels are mounted to brackets factory mortised into the top of the door. (Reducing the distance between the top of the door and the bottom of the track.)

Applies to:
(SSPE) Sliding Stacking Perpendicular
(SSPA) Sliding Stacking Parallel

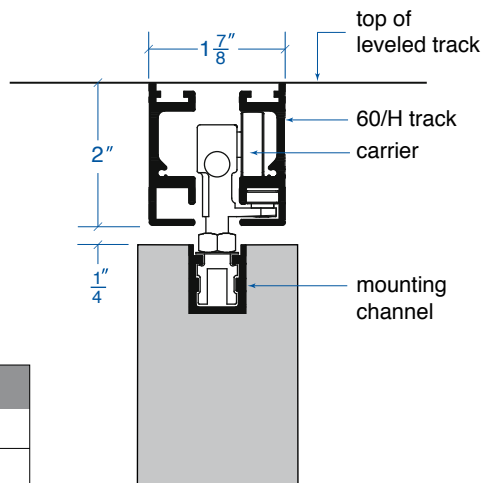

## Sliding Stacking

Our 60H sliding stacking track comes in clear anodized aluminum. Silent running nylon wheels on roller bearings are mounted to brackets factory mortised into the top of the door. (Reducing the distance between the top of the door and the bottom of the track.)

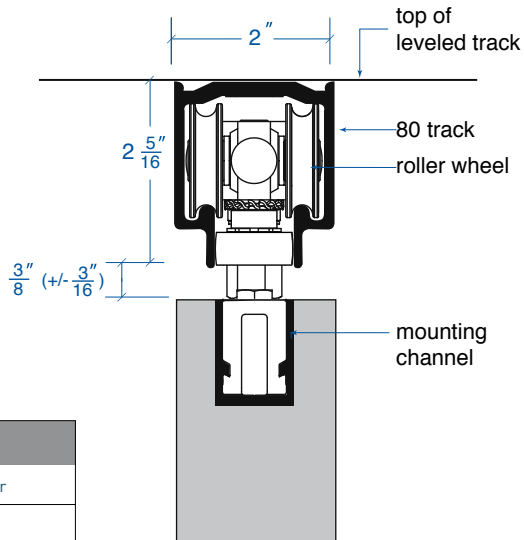

Applies to:
(FC) Folding Center
(FE) Folding End

### Folding

Our standard 80H folding track comes in clear anodized aluminum. Nylon wheels are mounted to brackets factory mortised into the top of the door.

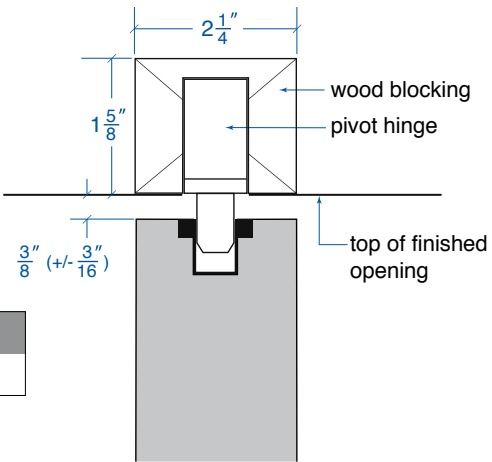

Applies to:
(PVC) Pivoting Center

### Pivot Center

Center pivot hardware leaves no exposed components and provides the greatest range of motion.

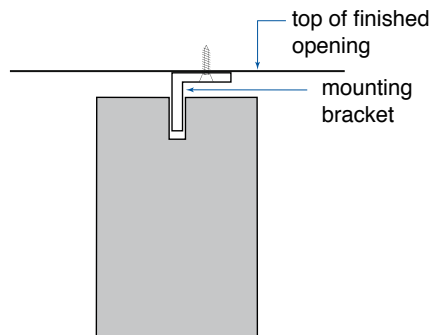

Applies to:
(FX) Fixed

### Fixed

Our fixed panel bracket comes in mill finish aluminum.